



ABE3UKA / ABE3UKAF

**3 W (min) Universal Ka-Band 27.5-31.0 GHz
BUC**

USER MANUAL





Table of contents

Introduction.....5

Receiving and inspection.....6

Equipment Damage or Loss

Return of Equipment

Preparing for installation.....7

Safety Precautions

General description.....8

Considerations

Securing the Block Up Converter

Installing the Block Up Converter.....9

LED Indicators, 10MHz Reference

Powering Options, Setting L.O., Setting Tx/Rx Frequencies

Recommended Test Equipment.....13

Technical Specifications.....14

Assembly and Installation.....15

Connections and Mounting Hardware

Functional Overview.....16



General

IF/RF Conversion and Amplification

Monitor and Control (optional)

Operation

Procedure.....17

Maintenance.....18

Preventive Care

Procedure

Block Up Converter Cooling System Preventive Maintenance

Performance Check

Troubleshooting

Out-of Warranty Repair

Appendix 1 Mechanical

Drawing.....20

Appendix 2 Spare Parts Order

Form.....21

Appendix 3 M&C

Commands.....22

Appendix 4 M&C Connection

Instructions.....27



Scope

This document covers the installation, operation, and maintenance of the ABE3UKA BUC. It contains information intended for engineers, technicians and operators working with the block up converter.

To make inquiries, or to report errors of fact or omission in this document, please contact **Actox Corporation** at toll free 866-888-6087.



INTRODUCTION

The ABE3UKA is a reliable, high quality, cost efficient stand-alone block up converter. The application for this block up converter is Ka-Band VSAT communication in an outdoor environment. This line of superior products, engineered using state of the art technology, is characterized by unparalleled durability and dependability.

This unique first ever 3W L-To Full Ka-Band Block Up Converter covers the O3B (27.65-29.1 GHz), Commercial (29.0-30.0 GHz) and Military (30.0-31.0 GHz) frequency bands. M&C (FSK) capability enables troubleshooting, monitoring and controlling the BUC. Unit provides 10MHz reference autosensing feature. The unit is ideal for portable and mobile applications.

KEY FEATURES

27.5 - 31.0 GHz

950 to 1,950 MHz

Smallest package size and weight

Quad L.O. (

switchable 26.55, 27.4, 28.05 and 29.05 GHz)

Auto-ranging 15 - 60 VDC

Low power consumption (38W max)

Digital temperature compensation

L.O. lock and amplifier LED

M&C – combined RS-232/485,

Ethernet (HTTP and SNMP ver.2 and 3 (optional)

FSK (optional)

RoHS compliant



Receiving and Inspection

The block up converter is designed to function outdoors and will arrive in a standard shipping container. Immediately upon receipt of the block up converter, check the packing slip against the actual equipment you have received. Inspect the shipping containers exteriors for visible damage incurred during shipping.

Handle the block up converter with extreme care. Excessive shock may damage block up converter's delicate internal components.

Using the supplied packing list, verify that all items have been received and undamaged during shipment. Verify that all items are complete. If there are any omissions or evidence of improper packaging, please notify **Actox Corporation** immediately.

Equipment Damage or Loss

Actox Corporation is not responsible for damage or loss of equipment during transit. For further information, contact the responsible transport carrier.

When declaring equipment as damaged during transit, preserve the original shipping cartons to facilitate inspection reporting.

Return of Equipment

When returning equipment to **Actox Corporation** for repair or replacement:

Identify, in writing, the condition of the equipment,
Refer to the Invoice, Purchase Order and the date the equipment was received.

Notify Actox Corporation RMA department of the equipment condition and obtain a Return Material Authorization (RMA) number and shipping instructions.

*Do not return any equipment without an RMA number.
This is important for prompt, efficient handling of the
returned equipment and of the associated complaint.*



Preparing for Installation

Before attempting to install or use the block up converter, we recommend that you first familiarize yourself with the product by reading through this manual. Understanding the operation of the system will reduce the possibility of incorrect installation, thereby causing damage or injury to yourself or others. The block up converter **must** be installed in accordance with the conditions and recommendations contained in the following sections.

Safety Precautions

Carelessness or mishandling of the block up converter may damage the unit causing serious injury to yourself or others. Please adhere to the following:

If your unit is equipped with an AC power cord and plug, do not tamper with, or attempt to reconfigure, the cord or plug supplied with the unit, as this can:

Result in personal injury;

Void the warranty;

Cause damage to the units or related equipment.



INSTALLATION AND OVERVIEW

General Description

This section describes the installation and theory of operation of the block up converter.

ABE3UKA is powered by +15~+60 VDC via IF cable.

The block up converter can be used as a stand-alone unit or in a redundant configuration.

Specifications

Table 1 summarizes the specifications of the ABE3UKA BUC. For mechanical specifications, refer to the outline drawing, Appendix 1.

General Considerations

The block up converter shall meet all specifications over full bandwidth and under all environmental conditions when terminated with a load of VSWR at 2:1 unless otherwise specified. All RF specifications shall be met within five minutes after applying power, except gain flatness, which shall be met after a warm-up period of ten minutes. During the warm-up period, the block up converter shall not exhibit any alarm or require an RF mute input signal to reset any alarm/fault latches.

Securing the block up converter

Align the block up converter output waveguide flange with the mating flange of the antenna feeder waveguide. Using the O-ring and hardware provided, connect the antenna feeder waveguide. Torque the flange screws to 16 inch-pounds (1.8 N-m). Attach the proper cables for waveguide for IF input and M&C to the corresponding connectors of the block up converter.

The cylindrical connectors are labeled clearly and have different pin layouts. It is impossible to incorrectly install the mating connectors.



Installing the Block-Up Converter

Tools and Test Equipment

Have on hand a standard electrician's tool kit and any tools listed in the antenna manufacturer's installation instructions.

Site Considerations

The BUC is designed to mount on the antenna. Locate and install the antenna according to instructions supplied by the antenna manufacturer. Choose an area that is free of extraneous interference from motors and electrical equipment and has a clear line of sight from the antenna to the satellite. Lightning arrestors should be used at the site to protect personnel and equipment.

Preparation

Mounting Considerations:

Optional Mounting Brackets are available that will facilitate mounting for most antennas.

The ODU must be mounted such that:

- Sufficient support is afforded to the BUC, the LNB and the Power supply to minimize the effects of antenna sway in strong winds.
- Air movement across the heat fins is possible.
- The length of the Power supply cables is taken into consideration in determining the mounting location of the power supply.

Throughout installation and during any polarization, azimuth or elevation adjustment, ensure that cables and waveguide are not crimped or pinched.



LED Indication

SSPA LED Green	All OK
SSPA LED Red	Summary Alarm
L.O. LED Green	L.O. is set to 26.55 GHz
L.O. LED Green Blinking	L.O. is set to 27.4 GHz
L.O. LED Yellow	L.O. is set to 28.05 GHz
L.O. LED Yellow Blinking	L.O. is set to 29.05 GHz
NO LED indicators	NO POWER
10MHz LED Green	External Detected
10MHz LED Green Blinking	Enabled

Connectors' Pin Assignment

Connector	Type	Pin #	Signal	Parameter
J1 "IF IN"	F-type female	N/A	IF Input 10 MHz Ref. IN	-0 dBm, max ±5 dBm
J2 "RF OUT"	WR-28	N/A	RF Output	38.0 dBm min

M&C Connection for 19-Pin

19 pin conn 9 pin conn
 GND G -----5
 TX 232 J -----2
 RX 232 E -----3

The following should be set on the COM Port:

Baud Rate: 9600bps
 Data bits: 8
 Stop bits: 1
 Parity: None
 HW Control: None

<u>INTERFACE_19PIN Connector</u>			
		X1 (19 pin)	
Signal type	Signal Name	Pin	Description
Ethernet	RX_P	C	
Ethernet	RX_N	P	
Ethernet	TX_P	L	
Ethernet	TX_N	N	
GND	GND	G	
RS-422/485	TX_B -	H	
RS-422/485	TX_A +	T	
RS-422/485	RX_B -	F	
RS-422/485	RX_A +	S	
RS-422/485/232 GND	RS_GND	G	
RS-232	TX_RS-232	J	
RS-232	RX_RS-232	E	
Control - TTL	/MUTE_IN	M	To Mute short Pin M & Pin V
Monitor - TTL	ALARM_IZ	B	Summary Fault -Alarm - TTL Low
Monitor - Analog (0 to 5V)	P_OUT_OUT	D	U=4,5V +- 0,5V - Pmax
Monitor/Control GND	WIRE_GND	V	



10MHz Reference

The BUC must receive a stable external 10MHz reference provided by a stable signal source such as a signal generator, satellite modem or injected externally with a Bias T (for example, ABT6ARN/ABT6ARF manufactured by Actox Corporation) or a similar bias T type.

Please make sure to check the sticker on the BUC for the appropriate power source before any power connections are performed.

Setting the L.O.

Switchable L.O. is mechanically changed by unscrewing the L.O. screw and pressing it in with any small object such as toothpick. If the BUC is equipped with M&C interface, the L.O. could be switching electronically with the appropriate M&C command.

Setting the TX and RX Frequencies

All transmit and receive frequencies are set in the modem.

For a direct connection to an L-band modem follow the manufacturer's instructions on setting the transmit and receive frequencies.

Ensure that it is safe to transmit prior to enabling the transmission.



Recommended Test Equipment

The following equipment or equivalent is recommended for installation and system alignment:

Equipment Type

Spectrum Analyzer	HP8563E
Digital Voltmeter	Fluke 8050
Adapter Waveguide to coax	C or Ku-band
RF cables	With calibrated insertion loss up to 15GHz
40 dB attenuator	High Power to match HPA output.

Assortment of cables, connectors and adapters (calibrated up to 18 GHz)

Ensure that the BUC TX output power is disabled to prevent accidental transmission interference with adjacent satellites or transponders before attempting to align or performing any other operation involving the ODU. Before attempting any system change, carefully evaluate the possible effects of the transmitted signal.



Table 1 Specifications

TECHNICAL SPECIFICATIONS	
RF frequency	27.5-31.0 GHz
Quad L.O.	26.55, 27.4, 28.05 GHz and 29.05 GHz
IF frequency	950 to 1,950 MHz
Output power	3W (+35 dBm min.)
IF connector	N-type or F-type
Power supply – auto-ranging	+15 VDC~+60 VDC via IF cable 38W max
Output interface	WR-28 Grooved
Gain	70 dB typ. 55 dB min.
TX Gain variation	± 0.5 dB over 40MHz ± 1.8 dB over full band
TX Gain stability over temperature range	± 1.5 dB typ., ± 1.8 dB max.
IMD3 (two tones)	-25 dBc max. 2 signal 5MHz apart at P-LINEAR
Spurious	-55 dBc max.
Spectral regrowth (QPSK at 1.5x and OQPSK at 1.0x symbol rate offset with 3dB back-off from rated output power)	-30 dBc
Requirement for external reference	via IF cable
frequency	10 MHz (sine-wave)
input power	-5 to +5 dBm @ input port
Phase noise	-55 dBc/Hz max. @ 10 Hz -65 dBc/Hz max. @ 100 Hz -75 dBc/Hz max. @ 1 KHz -85 dBc/Hz max. @ 10 KHz -95 dBc/Hz max. @ 100 KHz
Noise power density	-66dBm/Hz (max)
Transmit	-157dBm/Hz (max)
Receive	
M&C	RS-232/RS-485 and Ethernet (HTTP & SNMP)
FSK	Multiplexed on TX IFL, compatible with Comtech and Paradise
Status LED	SSPA MUTED
RED	SSPA OK
GREEN	All OK L.O. 26.55 GHz
GREEN	All OK L.O. 27.4GHz
GREEN BLINKING	All OK L.O. 28.05 GHz
YELLOW	All OK L.O. 29.05 GHz
YELLOW BLINKING	EXTERNAL DETECTED
Internal 10 MHz Auto-Detect	ENABLED
GREEN	
GREEN BLINKING	
Input V.S.W.R.	2 : 1 max
Output V.S.W.R.	2 : 1 max.
Mute	Shut off the BUC if L.O. unlocked
Temperature range (ambient)	
operating	-40 deg C to +55 deg C
storage	-55 deg C to +85 deg C
Dimensions & housing	179 (L) x 140 (W) x 58 (H) mm 7.0" (L) x 5.5" (W) x 2.28" (H)
Weight	1.99 kg (4.4 lbs) max.



Connections and Mounting Hardware

The IF input connection requires a coaxial cable with an F or N type connector. The RF output requires a waveguide with a WR-28 flat flange. An O-ring shall be used to seal the waveguide connection.

Assembly and Installation

Use the information in this section as a guide to assemble and install the block up converter. The specified humidity is up to 100% during operation. However, installation should be carried out in dry conditions, free of salt spray or excessive humidity. This will eliminate the possibility of moisture and other foreign substances from entering the output waveguide flange.

Only authorized technical personnel should perform the Installation and proper electrical hookups of the block up converter.

The block up converter is designed to operate in an outdoor environment and is waterproof when mounted in the correct orientation. To provide a sufficient airflow, the block up converter should be mounted with a minimum clearance of 3 inches on all four sides and the bottom. Adequate cooling for the block up converter will provide years of top performance.



Functional Overview

General

This section describes the block up converter functions in detail. The functional overview explains the RF amplification, monitor & control and power distribution.

IF/RF Conversion and Amplification

The IF Input requires a signal with a 10MHz reference, and 15-60 VDC power source. 2-4.5Amps nominal enters the BUC by a coaxial cable, converted to Ka-Band by the BUC and goes through an internal isolator and reject filter, which provides a good VSWR at the input. Under normal operation, the RF amplifier will amplify the RF Input signal level up to a power level of 35 dBm or 3 Watts CW minimum.

To achieve the rated output power of the RF Amplifier, provide the necessary gain and low insertion loss. The amplified signal is transmitted through the output waveguide section to a satellite up-link system.

Monitor and Control (optional)

The block up converter may have a RS-485 and RS-232 serial interface. With this option the block up converter can communicate to the indoor unit or redundancy control block up converter via RS-485 or RS-232.

The control system can provide the following M&C functions:

- BUC Alarm (via RS-485/RS-232): when an input BUC within the block up converter system current draw is below 0.3A, a BUC alarm signal will be transmitted via the RS-485/RS-232 serial interface.
- Mute Control (via RS-485/RS-232)
- Mute Control (via hardware line): TTL high level signal will mute a block up converter
- Output Power Monitoring: 20 dB dynamic range (via RS-485/RS-232)
- Base Plate Temperature Monitoring (via RS-485/RS-232)



Operation

It shall be performed by authorized personnel prior to maintenance and/or repair.

Procedure

Verify that the installation procedure described was completed. A complete physical check of the customer's system is suggested.

*The output power available at the output waveguide flange is extremely hazardous. Under **no circumstances** should block up converter be operated without the waveguide feed or a high power load attached. Do not operate this equipment in the presence of flammable gases or fumes. Failure to observe this precaution will result in personal injury. Safe and careful installation of this block up converter will eliminate the possibility of accidents and provide years of top performance.*

Verify the antenna feed waveguide connection is properly done before the block up converter is energized.

The block up converter can withstand any source or load VSWR. However, the block up converter will meet all specification requirements only if the source/load VSWR is sufficient. Normal operation is not possible if the antenna feeder VSWR is greater than 2:1.

Turn ON the power and allow a warm up period of twenty minutes before operating the block up converter. This will assure stable gain and power. The block up converter can function with a coupler when a direct measurement of the output power is made.



Maintenance

This section contains information on how to maintain, troubleshoot and repair the block up converter. The block up converter is extremely reliable, requiring very little preventive maintenance, or repair. Should there be a malfunction, this section also contains technical information to help diagnose basic failures.

Preventive Maintenance

Shut down the block up converter before disassembly and remove all cables and connectors. Failure to observe this precaution may result in personal injury or death. This includes the removal of any RF power originating from other system components.

When the block up converter is in the **hot stand-by mode** in a redundant system, switch it to the operation mode at least once every three months.

When the block up converter is in the **cold stand-by mode** in a redundant system, switch it to the operation mode at least once every three months.

Block up converter Cooling System Preventive Maintenance

Preventive maintenance is limited to checking the performance of the block up converter cooling system. No electrical or mechanical adjustments are required for normal operation.



Performance Check

Verify the system is properly set up.

It is recommended to measure the following parameters for ensuring that the block up converter is in good working condition:

- Gain and Gain flatness
- RF load VSWR and RF source VSWR
- Two-Tone Inter-modulation Distortion
- Return Loss at connectors of the block up converter

Using a Source and an IF input signal level within the small signal region of the block up converter, measure the power level at connectors IF or MS connector. Plot the swept response on a test data sheet. From the plot, determine gain and gain flatness.

Plot the swept return loss for both the IF Input and RF Output signals on a test data sheet. From the plot determine the return loss.

From the output power measurements determine rated output power. Record value on a test data sheet.

Measure the Two-tone Inter-modulation Suppression using two equal signals separated by 5 MHz. Record value on test data sheet.

Cable connection and disconnection shall be done carefully to avoid physical damage to the cables and connectors, which may cause intermittent problems in the future.

Symptom	Action
Fails performance test	Check power source, RF source, cabling and connectors. Check LED indicators for status and if the light is red contact Actox Corporation. If we are not able to assist you remotely, return block up converter to Actox Corporation after RMA number has been issued.

A non-warranty and out-of-warranty repair service is available from Actox Corporation for a nominal charge. The customer is responsible for paying the cost of shipping the BUC both to and from Actox Corporation for these repairs.

Appendix 1

Mechanical Drawing

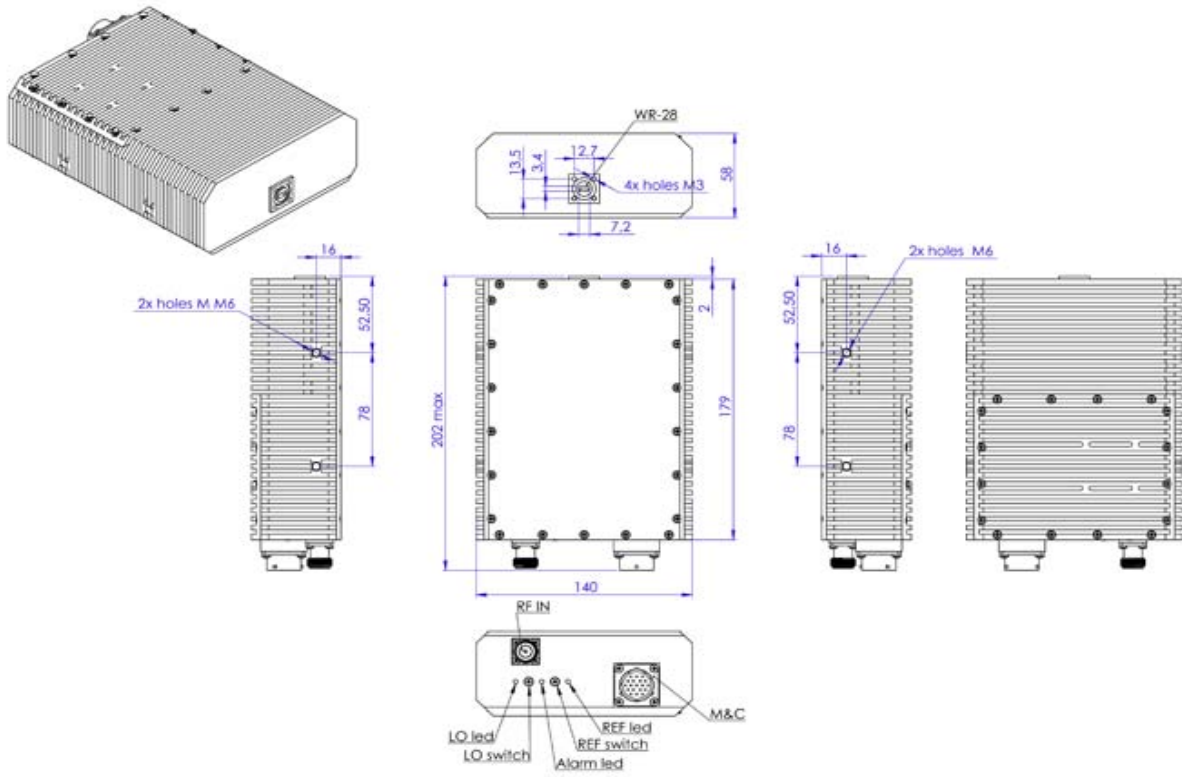



Appendix 2

Spare Parts

The following sheet can be copied and used as a fax form to order the required spare parts. Please make sure to include all identifying information to facilitate the processing of your order. The order may be sent via email to the following address.

Fax: 1-866-888-6087

Email: mark_moore@actox.com

For additional information, please contact our customer service department at:
(619)906-8893 or 1-866-888-6087

Actox Corporation <i>designers and manufacturers of telecom & wireless products</i>					
Spare Parts Order Form		ABE3UKA Universal Ka-Band BUC			
From:					
Place By:		Signature:			
Telephone:					
Fax		Email:			
Part Description		Part Number	Quantity	Unit Price*	Line Total*

Fax to: Customer Service 1-866-888-6087



Appendix 3

M&C Commands

Reply	Packet format	Explanation	Interpretation	Examples
ACK (Acknowledge)	7E FX E0 ZZ 7F	Acknowledge that the received packet was properly processed.	X = Device address of the packet source device. ZZ = CRC.	1) reply: 7E FF E0 E0 7F (ACK reply sent from the BUC)
NACK (Not Acknowledge)	7E FX F1 YY ZZ 7F	Indicate that a problem was encountered with the received packet.	X = Device address of the packet source device. YY = Error code (03 = Incorrect CRC 18 = Unrecognized command 30 = Set command attempted on a restricted database element) ZZ = CRC.	1) reply: 7E FF F1 03 F2 7F (NACK reply sent from the BUC for an invalid CRC) 2) reply: 7E FF F1 18 E9 7F (NACK reply sent from the BUC for an unrecognized command).

Command	Packet format	Explanation	Possible replies	Interpretation	Examples
Get Device Temperature	7E FF 02 06 06 02 7F	Query device for current temperature	Update Device Temp: 7E FF 84 06 06 TT TT ZZ 7F	TT TT = Device temp in °C + 273. ZZ = CRC.	1) cmd: 7E FF 02 06 06 02 7F reply: 7E FF 84 06 06 01 02 87 7F (Temp = 0x0102 = 0d258 – 273 = -15°C) 2) cmd: 7E FF 02 06 06 02 7F reply: 7E FF 84 06 06 01 34 B1 7F (Temp = 0x0134 = 0d308 – 273 = +35°C)
Get Power Supply Temperature	7E FF 02 06 07 03 7F	Query device for current power supply temperature	Update Device PS Temp: 7E FF 84 06 07 TT TT ZZ 7F	TT TT = PS temp in °C + 273. ZZ = CRC	1) cmd: 7E FF 02 06 07 03 7F reply: 7E FF 84 06 07 01 02 86 7F (Temp = 0x0102 = 0d258 – 273 = -15°C) 2) cmd: 7E FF 02 06 07 03 7F reply: 7E FF 84 06 07 01 34 B0 7F (Temp = 0x0134 = 0d308 – 273 = +35°C)
Get Output Power	7E FF 02 17 FF EA 7F	Query device for current output power	Update Output Power: 7E FF 84 17 FF PP PP ZZ 7F	PP PP = Output power in 10 x dBm. ZZ = CRC.	1) cmd: 7E FF 02 17 FF EA 7F reply: 7E FF 84 17 FF 01 2C 41 7F (Power = 0x012C = 0d300 = 30.0dBm.) 2) cmd: 7E FF 02 17 FF EA 7F reply: 7E FF 84 17 FF 01 A0 CD 7F (Power = 0x01A0 = 0d416 = 41.6dBm.)
Get Gain	7E FF 02 18 FF E4 7F	Query device for current gain. Note: value is depending of attenuation settings.	Update Gain: 7E FF 84 18 FF GG GG ZZ 7F	GG GG = Gain in 10 x dB. ZZ = CRC.	1) cmd: 7E FF 02 18 FF E5 7F reply: 7E FF 84 18 FF 02 8A 69 7F (Gain = 0x028A = 0d650 = 65.0dB.) 2) cmd: 7E FF 02 18 FF E5 7F reply: 7E FF 84 18 FF 01 F9 F7 7F (Gain = 0x01F9 = 0d505 = 50.5dB.)



Get Attenuation	7E FF 02 18 FE E4 7F	Query device for current attenuation	Update Attenuation: 7E FF 84 18 FE GG GG ZZ 7F	AA AA = Attenuation in 10 x dB. ZZ = CRC.	1) cmd: 7E FF 02 18 FE E4 7F reply: 7E FF 84 18 FE 00 C8 AA 7F (Atten = 0x00C8 = 0d200 = 20.0dB.) 2) cmd: 7E FF 02 18 FE E4 7F reply: 7E FF 84 18 FE 00 69 0B 7F (Atten = 0x0069 = 0d105 = 10.5dB.)
Get Low Power Alarm Threshold	7E FF 02 10 10 02 7F	Query device for current low power alarm threshold	Update Low Power Alarm Threshold: 7E FF 84 10 10 TT TT ZZ 7F	TT TT = low power threshold in 10 x dBm. ZZ = CRC. Note: zero value means low power alarm disabled	1) cmd: 7E FF 02 10 10 02 7F reply: 7E FF 84 10 10 01 AE 2B 7F (Thresh = 0x01AE = 0d470 = 47.0dBm.) 2) cmd: 7E FF 02 10 10 02 7F reply: 7E FF 84 10 10 00 00 84 7F (Thresh = 0x0000 = 0d00 = alarm is disabled.)
Get Power Supply Voltage	7E FF 02 06 10 14 7F	Query device for power supply voltage	Update PS Voltage: 7E FF 84 17 FF PP PP ZZ 7F	VV VV = PS voltage in 10 x V. ZZ = CRC.	1) cmd: 7E FF 02 06 10 14 7F reply: 7E FF 84 06 10 01 2C BF 7F (Power = 0x0064 = 0d100 = 10.0V.) 2) cmd: 7E FF 02 06 10 14 7F reply: 7E FF 84 06 10 00 63 F1 7F (Power = 0x0063 = 0d99 = 9.9V.)

Command	Packet format	Explanation	Possible replies	Interpretation	Examples
Get Power Supply Current	7E FF 02 06 11 15 7F	Query device for power supply current	Update PS Current : 7E FF 84 06 11 PP PP ZZ 7F	CC CC = PS current in 10 x A. ZZ = CRC.	1) cmd: 7E FF 02 06 11 15 7F reply: 7E FF 84 06 11 00 AD 3E 7F (Power = 0x00AD = 0d173 = 17.3A.) 2) cmd: 7E FF 02 06 11 15 7F reply: 7E FF 84 06 11 00 97 04 7F (Power = 0x0097 = 0d151 = 15.1A.)
Get Mute Status	7E FF 02 06 01 05 7F	Query device for mute status	Update Mute Status: 7E FF 84 06 01 00 MM ZZ 7F	MM = Mute status (0 = enabled; 1 = muted). ZZ = CRC.	1) cmd: 7E FF 02 06 01 05 7F reply: 7E FF 84 06 01 00 83 7F (Device is enabled.) 2) cmd: 7E FF 02 06 01 05 7F reply: 7E FF 84 06 01 00 01 82 7F (Device is muted.)
Get Device Address	7E FF 02 03 04 05 7F	Query for device address	Update device address: 7E FF 84 03 04 00 XX ZZ 7F	XX = Device address. ZZ = CRC.	1) cmd: 7E FF 02 03 04 05 7F reply: 7E FF 84 03 04 00 0A 89 7F (Device address = 0xA) 2) cmd: 7E FF 02 03 04 05 7F reply: 7E FF 84 03 04 00 0E 8D 7F (Device address = 0xE)
Get Over Temperature Alarm	7E FF 02 00 02 00 7F	Query device for over temperature alarm	Update over temperature alarm: 7E FF 84 00 02 00 XX ZZ 7F	XX = Alarm state (0 = no alarm; 1 = alarm). ZZ = CRC.	1) cmd: 7E FF 02 00 02 00 7F reply: 7E FF 84 00 02 00 01 87 7F (Over temp alarm is raised) 2) cmd: 7E FF 02 00 02 00 7F reply: 7E FF 84 00 02 00 00 86 7F (Over temp alarm is clear)
Get Low Power Alarm	7E FF 02 00 05 07 7F	Query device for low power alarm	Update low power alarm: 7E FF 84 00 05 00 XX ZZ 7F	XX = Alarm state (0 = no alarm; 1 = alarm). ZZ = CRC.	1) cmd: 7E FF 02 00 05 07 7F reply: 7E FF 84 00 05 00 01 80 7F (Low power alarm is raised) 2) cmd: 7E FF 02 00 05 07 7F reply: 7E FF 84 00 05 00 00 81 7F (Low power



					alarm is clear)
Get Summary Alarm	7E FF 02 00 0F 0D 7F	Query device for summary alarm	Update summary alarm: 7E FF 84 00 0F 00 XX ZZ 7F	XX = Alarm state (0 = no alarm; 1 = alarm). ZZ = CRC.	1) cmd: 7E FF 02 00 0F 0D 7F reply: 7E FF 84 00 0F 00 01 8A 7F (Summary alarm is raised) 2) cmd: 7E FF 02 00 0F 0D 7F reply: 7E FF 84 00 0F 00 00 8B 7F (Summary alarm is clear)

Command	Packet format	Explanation	Possible replies	Interpretation	Examples
Set Mute Control	7E FF 14 13 01 00 MM ZZ 7F	Mute / Unmute the device.	ACK NACK	MM = Mute control (1 = Mute; 0 = enable). ZZ = CRC	1) cmd: 7E FF 14 13 01 00 01 07 7F reply: ACK (Mute device) 2) cmd: 7E FF 14 13 01 00 00 06 7F reply: ACK (Enable device)
Set Attenuation	7E FF 14 18 FE AA AA ZZ 7F	Set internal attenuator value Note: value is internally rounded with 1dB discrete, value range is 0-30 dB.	ACK NACK	AA AA = Attenuation in 10 x dB. ZZ = CRC.	1) cmd: 7E FF 14 18 FE 00 C8 3A 7F reply: ACK (Set attenuator to 30.0dB = 0d200 = 0x00C8) 2) cmd: 7E FF 14 18 FE 00 69 9B 7F reply: ACK (Set attenuator to 10 dB = 0d105 = 0x0069)
Set Low Power Alarm Threshold	7E FF 14 10 10 TT TT ZZ 7F	Set low power alarm threshold Note: zero value means low power alarm disabled	ACK NACK	TT TT = Low power threshold in 10 x dBm. ZZ = CRC.	1) cmd: 7E FF 14 10 10 00 C8 DC 7F reply: ACK (Set threshold to 47.0dB = 0d470 = 0x01AE) 2) cmd: 7E FF 14 10 10 00 00 14 7F reply: ACK (Set threshold to 0.0 dB = 0d00 = 0x0000) – alarm disabled
Set Device Address	7E FF 14 03 04 00 XX ZZ 7F	Set device address Note: (0 ≤ address ≤ 0xE)	ACK NACK	XX = Device address. ZZ = CRC.	1) cmd: 7E FF 14 03 04 00 0A 19 7F reply: ACK (Set device address to 0xA) 2) cmd: 7E FF 14 03 04 00 0E 1D 7F reply: ACK (Set device address to 0xE)

Command	Packet format	Explanation	Possible replies	Interpretation	Examples
Get L.O. Frequency	7E FF 02 10 12 ZZ 7F	Query device for L.O. Frequency	Update L.O. frequency 7E FF 84 10 12 QQ QQ ZZ 7F	QQ QQ =L.O. Frequency In HEX format ZZ = CRC	1.cmd: 7E FF 02 10 12 ZZ 7F reply: 7E FF 84 10 12 13 24 ZZ 7F (Frequency = 0x13 24=0d4900 MHz) reply: 7E FF 84 10 12 15 7C ZZ 7F (Frequency= 0x15 7C = 0d5500 MHz)
Get L.O. 1 or L.O. 2	7E FF 02 10 11 ZZ 7F	Query device for L.O. 1 or L.O. 2.	Update L.O.1 or L.O.2 7E FF 84 10 11 00 LL ZZ 7F	LL = 00 = L.O.1 LL = 01 = L.O.2 ZZ = CRC	1.cmd: 7E FF 02 10 11 ZZ 7F reply: 7E FF 84 10 11 00 00 ZZ 7F (LL = 00 = L.O.1) reply: 7E FF 84 10 11 00 01 ZZ 7F (LL = 01 = L.O.2)
Set L.O. 1 Set L.O. 2	7E FF 14 10 11 00 00 ZZ 7F 7E FF 14 10 11 00 01 ZZ 7F	Set the frequency of L.O. 1 Set the frequency of L.O. 2	ACK 7E FX E0 ZZ 7F	X = device address of the packet source device ZZ = CRC	1.Reply 7F FF E0 ZZ 7F ACK reply sent from the device

NOTE: The packets shown are based on the assumption that the Booster device address is set to 0xF. To modify the commands for different addresses, the Dest/Src byte and the CRC byte will have to change in all packets.



M&C Serial Protocol.

SCI Packet Byte Description

◆ **STX** is the start transmission byte (defined as 0x7E). This byte is used to determine the start of a packet.

◆ **Dest/Src Address** contains the destination address in the high nibble and the source address in the low nibble. The destination address is the address of the device which is to process the packet. The source address is the address of the device which sent the packet. Note that the device address of the customer interface device is always = 0x0F.

◆ **CMD/Len** contains the packet command in the high nibble and the number of bytes in the data portion of the packet in the lower nibble.

The following commands may be sent by the customer interface device:

GET (command high nibble = 0x0) Request the current value of a database element.

SET (command high nibble = 0x1) Set the database element to the specified value.

The following commands may be returned to the customer interface device:

UPD (command high nibble = 0x8) Return the current value of a database element.

ACK (command high nibble = 0xE) Acknowledge a received packet.

NACK (command high nibble = 0xF) Reject a received packet (Not ACKnowledge).

◆ **Data1 - Datan** contains the packet payload. The value of the data bytes is specific to the command and will be covered in following sections.

◆ **CRC** is the cyclic redundancy check and is calculated by performing a byte-wise exclusive OR of the Dest/Src address byte, Cmd/Len byte and all data bytes. A bit-wise inversion is then applied to the CRC before being inserted into the packet.

◆ **ETX** is the end transmission byte (defined as 0x7F). This byte is used to determine the end of a packet.

Default Address Values

The customer interface device must always be assigned address 0xF.

The Transceiver device address is factory defaulted to 0xF. It may be set by the customer using the SET Transceiver Address command (refer to SET Control Command List).

The Booster device address is factory defaulted to 0xE. It may be set by the customer using the SET Booster Address command (refer to SET Control Command List).

Command / Reply Packet Sequencing

The Transceiver will never send a packet to the customer interface device unless a command is received. In other words, the Transceiver will not speak unless spoken to.

Default Reply Packet Format

This section identifies the packet format the ACK (Acknowledge) and NACK (Not acknowledge) replies which may be sent to the customer interface device in response to a received command.



CRC Calculation Example

To send a command to read the temperature (database element = 0x0606) from the Booster (device address 0x0F), the command is:

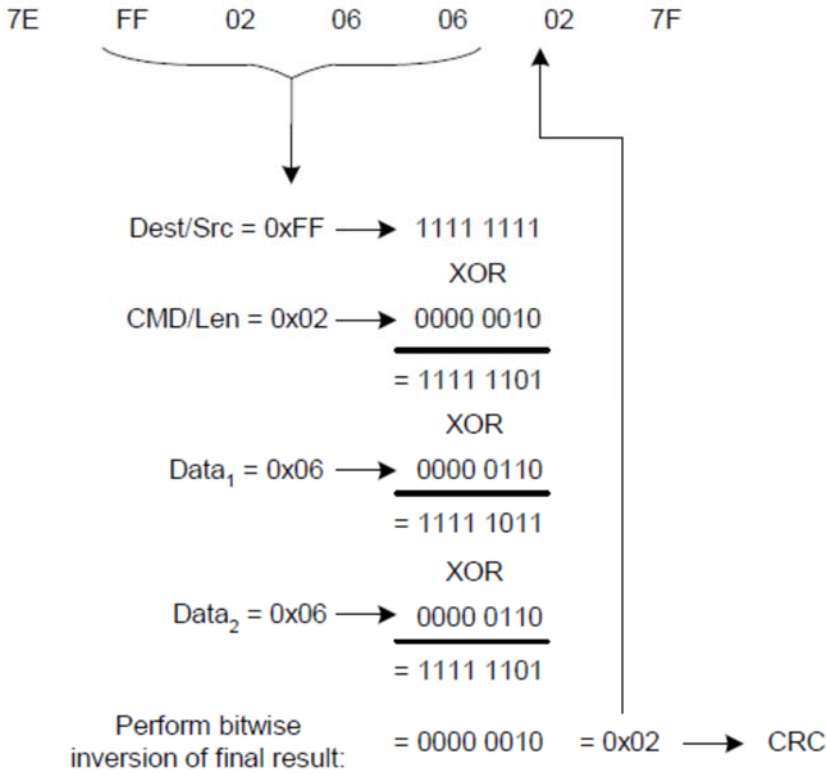

Example Only

```

7E FF 02 06 06 02 7F
Dest/Src = 0xFF
CMD/Len = 0x02
1111 1111
0000 0010
XOR
= 1111 1101
Data1 = 0x06 0000 0110
XOR
= 1111 1011
Data2 = 0x06 0000 0110
XOR
= 1111 1101
Perform bitwise
inversion of final result: = 0000 0010 = 0x02 CRC

```

Appendix 4

BUC 19 pin connector for a PC / Laptop

BUC connection to PC carried by cable with 19 pin female connector (fig.1) on the one side and RJ45 (fig. 2), two DB9 (fig. 3) female connectors: RS232 and RS485 on the other side.

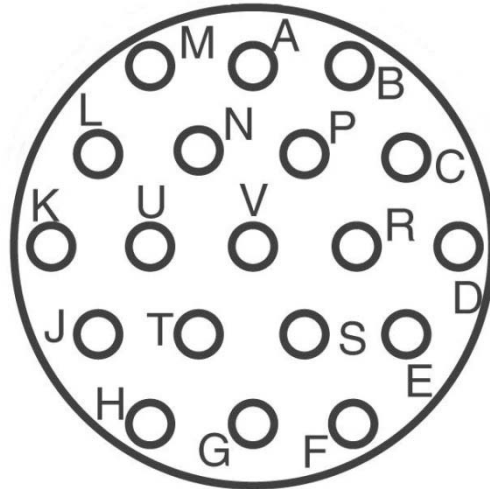

Figure 1.1 — 19 pin connector configuration

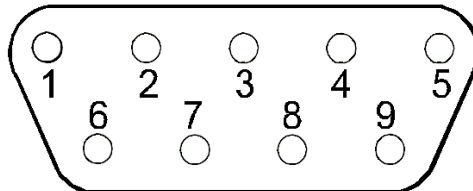

Figure 1.2 — DB9 connector configuration

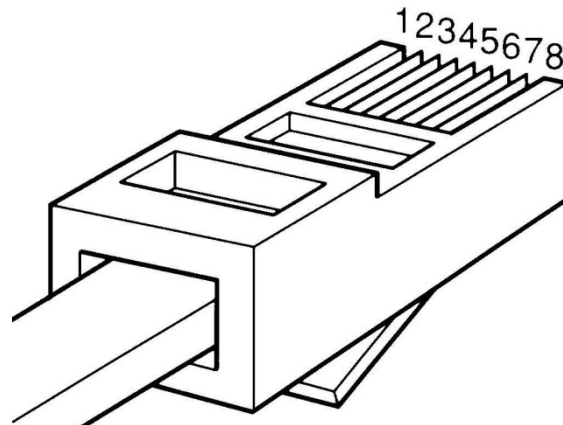



Figure 1.3 — RJ45 connector configuration

PC interface name	From PC Interface pin	Pin name	From BUC pin
	NC	NC	R
	NC	NC	U
	NC	NC	K
Ethernet	3	RX P	C
	6	RX N	P
	1	TX P	L
	2	TX N	N
RS-485	5	GNDISO	A
	4	TX B	H
	3	TX A	T
	1	RX B	F
	2	RX A	S
RS-232	5	GNDISO	G
	2	TX RS-232	J
	3	RX RS-232	E
	NC	MUTE IN	M
	NC	ALARM IN	B
	NC	P OUT OUT	D
	NC	GNDISO	V

Table 1 — BUC to PC Cable Connection



BUC User Manual via PC

Run *NewBuc v.301* on your PC, when it opened you will see next window:

Device Name: Model Number:

Operation Time: Serial Number:

Monitor Settings

Output Power: W dBm

Gain: dB

Internal Temp: C Attenuation: 0.0 dB

Internal Voltage: V MUTE:

Current Draw: A 10 MHz:

L.O. SSPA 10 MHz SUM Alarm 10 Mhz -5 V PLL HPA Temp

Programm Address: 2 COM1 19200

COM-port CLOSED

Figure 2.1 — Start window with **Monitor** Tab

In the head there is device information, such as:

- **Device Name:** Name that you can give to your device (You can change device name in the tab **Settings**)
- **Model Number:** Read only. Factory set. Presents model of your device.
- **Operation Time:** The time that was passed since **BUC** was switch on.
- **Serial Number:** Read only. Factory set. Each unit has a unique number.

Below the head you can find two tabs: **Monitor** and **Settings**.

Monitor Tab

Tab **Monitor** provides online telemetry of **BUC**:

- **Output Power:** Display the output detector value in W and dBm.
- **Internal Temp:** Display the **BUC** Hot spot temperature in degree Celsius.
- **Internal Voltage:** Display the **BUC** input voltage value in volts.
- **Current Draw:** Display the **BUC** input current value in amperes.
- **Gain:** Display the **BUC** gain value in dB.
- **Attenuation:** Configurable parameter. Controls gain attenuation. For change attenuation lever (from 0 db to 20 db) fill new value in the field and click button **Set** to apply changes.

- **MUTE:** Configurable parameter. Stand-by **BUC** (On/Off output transmit). Includes two modes: **Mute** – output transmitter will be shut down until demand; **Unmute** – output transmitter will be always switched. For changing mode click the button **Set**.
- **10 MHz:** Configurable parameter. Allows switch reference frequency. Includes two modes: **Internal** and **External**. For changing mode click the button **Set**.

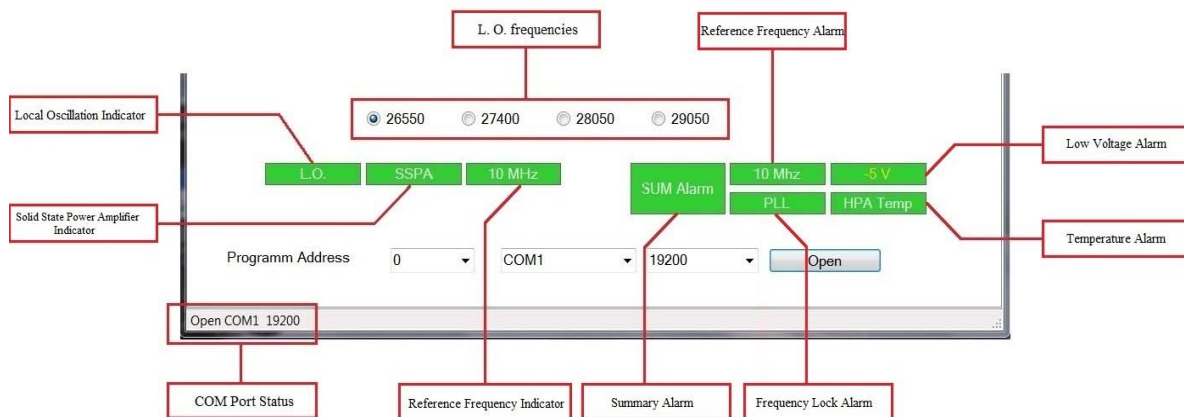

Figure 2.2 — Program Indicators

- **L.O.** — indicates **Local Oscillation**, which sets above. Indication change according to the established **L.O**:
 - Green color – frequency 26550Hz;
 - Blinking green color – frequency 27400Hz;
 - Yellow color – frequency 28050Hz;
 - Blinking yellow color – 29050Hz;
- **SSPA** — indicates **Solid State Power Amplifier** connection.
- **10 MHz** — indicates **Reference Frequency**.
 - Green color – internal;
 - Blinking color – external;
- **SUM Alarm** — indicates summary failure of system.
- **10 MHz** — indicates red if **Reference Frequency** failure or green if everything correct.
- **PLL** — indicates red if **10MHz** reference is missing or green if everything correct.
- **-5 V** — indicates red if **Input Voltage Level** is lower than necessary or green if everything correct.
- **HPA Temp** — indicates red if device hot spot as exceeded 85°C or green if it lower.

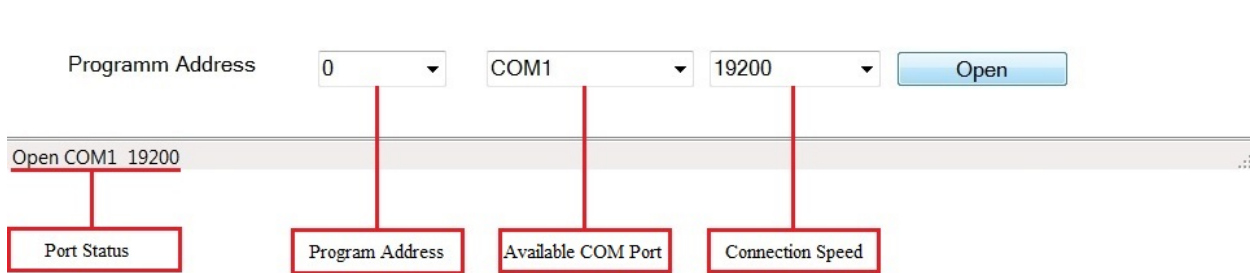

Figure 2.3 — Program Address Configurations

Settings Tab

Tab **Settings** open access to change BUC configurations. The tab indicated on the fig. 2.4

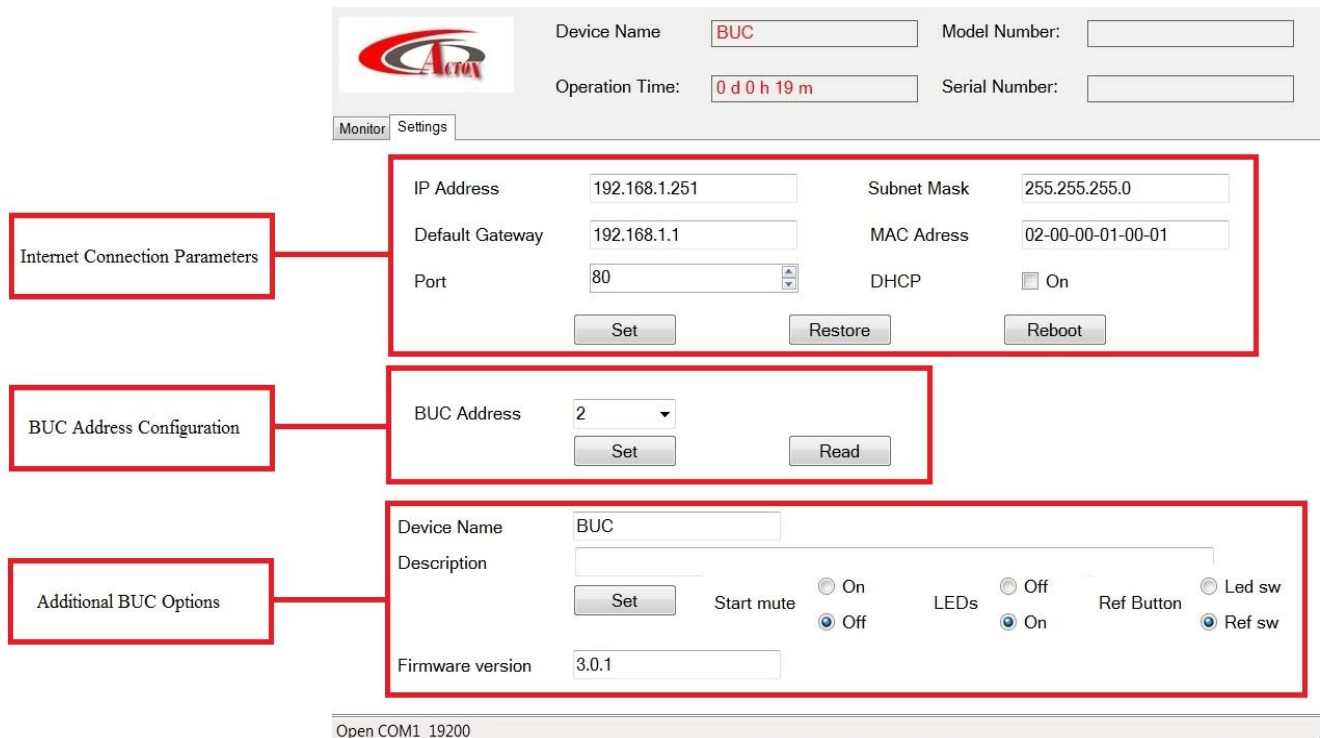

Figure 2.4 — Start window with **Settings** Tab

Internet Connection Parameters:

- **IP Address:** Configurable. Factory default, 192.168.1.250;
- **Default Gateway:** Configurable. Factory default, 192.168.1.1;
- **Port:** Configurable. Factory default, 80;
- **Subnet Mask:** Configurable. Factory default, 255.255.255.0;
- **MAC Address:** Configurable. Factory default, 02-00-00-01-00-02;
- **DHCP:** Configurable. Factory default, disable;

BUC Address Configuration: Displays current **BUC** address. Button **Read** allows find out current address.

Additional BUC Options:



- **Device Name:** Let you rename your device;
- **Description:** Write here description or notes about your device;
- **Start Mute:** Option that lets you to start **BUC** muted. Configurable. Factory default, disable.
- **LED`s:** Option that lets you to switch on/off LED`s on dashboard. Configurable. Factory default, enable.
- **Ref Button:** Changes button functions:
 - **Led sw:** switch on/off LED`s on dashboard;
 - **Ref sw:** switch on/off auto detect function (if **BUC** works on internal reference frequency). Configurable. Factory default, **Ref sw**.
- **Firmware version:** Displays current version of BUC`s firmware.

NOTE

For correct work of the device program version must be equal or higher than firmware version.



BUC User Manual via Ethernet

For connection with BUC via Web use internet browser. You will see next page:

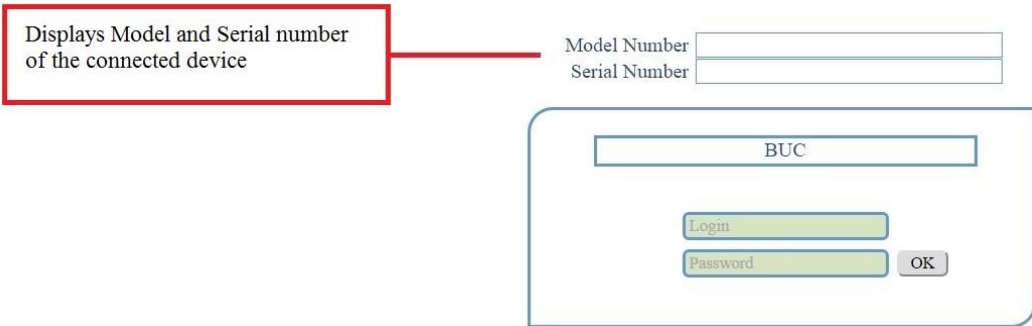
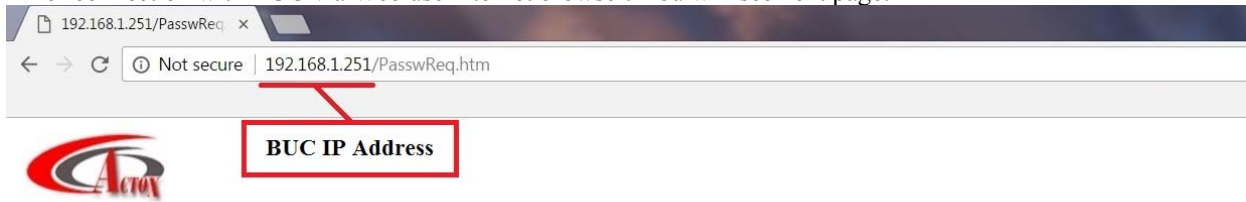

Figure 3.1 — Start Page

For log in type your login and password in appropriate fields. There are two access levels: **User** and **Admin**. By default User's access level ID: Login: **User**, Password: **1234**; Admin's access level ID: Login: **Admin**, Password: **1234**;

When you enter will be loaded next page:

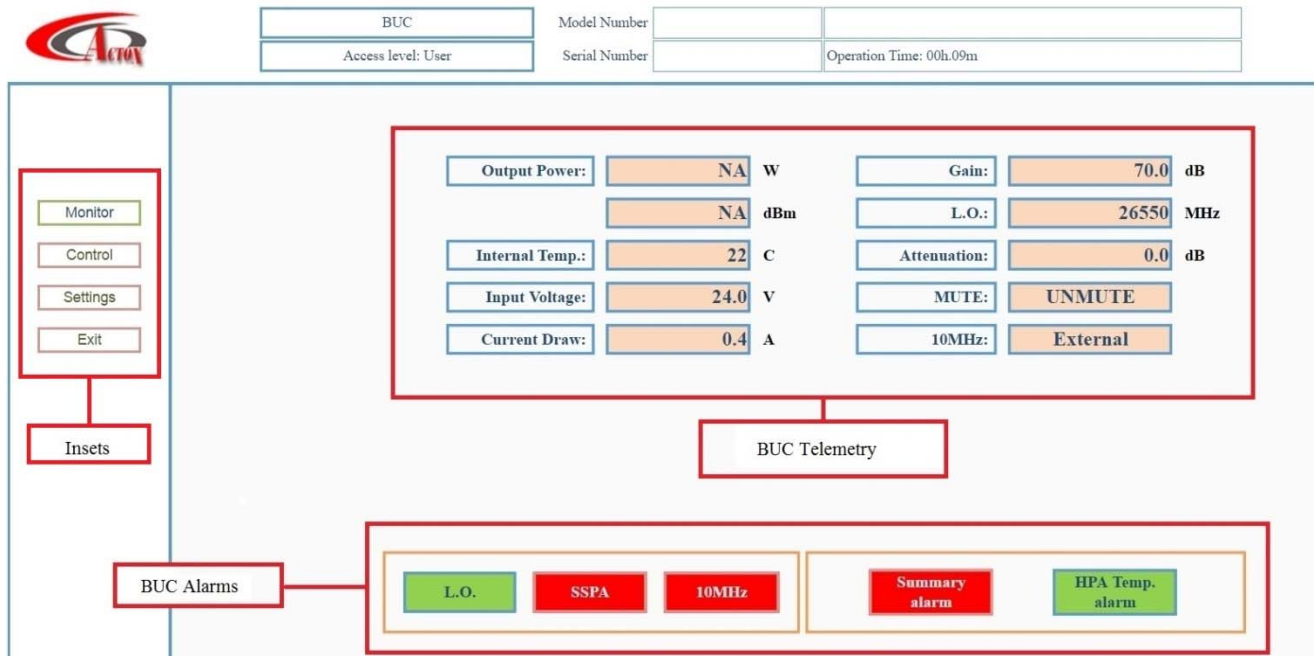

Figure 3.2 — Monitor Tab



In the head of the page you will find information about your device (**BUC Name**, **Model** and **Serial Number**) and current access level (**User** or **Admin**).

On the tab **Monitor** situated BUC telemetry and BUC Alarms. Tab **Monitor** is functionally similar to the tab **Monitor** from the program NewBuc v.301 (see fig. 2.1). This tab looks the same for all access levels.

To change the settings switch on the tab **Control** on the tab panel.

The screenshot shows the 'Control' tab interface. At the top, there's a header with 'BUC' and 'Access level: User'. Below this are fields for 'Model Number', 'Serial Number', and 'Operation Time: 00h.09m'. The main control area includes: 'MUTE: UNMUTE Sw', 'Gain: 70.0 dB', '10MHz: External Sw', 'Attenuation: 0.0 dB', 'LO: 26550 MHz' (selected), '27400 MHz', '28050 MHz', '29050 MHz', and 'Set' buttons. At the bottom, there are status indicators for 'L.O.', 'SSPA', '10MHz', 'Summary alarm', and 'HPA Temp. alarm'.

Figure 3.3 — Control Panel

On this panel you can configure options from the **Monitor** tab.

- **MUTE**: to change mode from **MUTE** to **UNMUTE** click button **Switch**;
- **10MHZ**: to change mode from **INTERNAL** to **EXTERNAL** click button **Switch**;
- **L.O.**: choose right Local Oscillation frequency and click button **Set** to apply changes;
- **Attenuation**: for change attenuation lever fill new value in the field and click button **Set** to apply changes;
- **Gain**: displays gain value after attenuation;

This tab looks the same for all access levels.

Tab Settings contains information about connection parameters and administration panel for changing user's login and password. Tab looks different for different access levels. Tab for user and admin access levels shown on the fig. 3.4 and 3.5:



Figure 3.4 — Settings Panel (Access Level: User)

This tab conditionally divided into two panels. Left panel contains information about current connection parameters (DHCP status, IP Address, Subnet Mask, Default Gateway, Port and MAC Address), connection speed (for RS232 and RS485 ports) and BUC address. Right panel designed to change login configurations, such as Name and Password.

Figure 3.5 — Settings Panel (Access Level: Admin)

Admin Access level gives wider range of configurations. In this access level available several new parameters, such as:

- **DHCP:** you can switch on/off DHCP;
- **SMNP Manager IP:** set IP address of the computer that will receive Traps from your device. The Trap is data package that consist reports about crushes in **BUC**. Traps are received by SNMP browser. As a SNMP browser recommended to use *ManageEngine MibBrowser*. In order to set new SNMP Manager IP type address



in the green field and push the button Set. To apply changes you must reboot your device!

- **New Community:** you can set password for SNMP browser. Without this password you wouldn't get access to BUC via SNMP browser. Type new password in the green field. In field **Confirm New Community** repeat this password and push button Save to save password.
- **Device Name:** you can set new name for your device.

Also in **Admin Access level** you can change device connection parameters, such as **IP Address**, **Subnet Mask**, **Default Gateway**, **Connection Port**, **MAC Address** and **BUC Address**.

In right panel you can not only change own login configuration, but also restore **Name** and **Password** for User Access level.